

# SIGMA

## SIGMA 40mm T1.5 FF Technical Specifications

### Lens construction

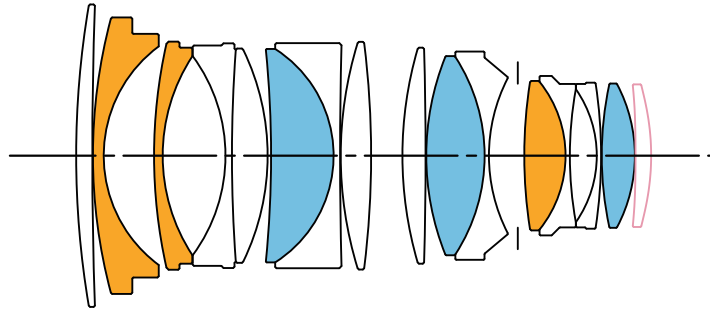

16 Elements in 12 Groups

■:FLD ("F" Low Dispersion) Glass ■:SLD (Special Low Dispersion) Glass □:Aspherical Lens

### Specifications

FF High Speed Prime Line		40mm T1.5 FF
Focal Length		40mm
Aperture(T)		T1.5 to T16
Number of Diaphragm Blades		9 (Rounded diaphragm)
Close Focus <sup>1</sup>		0.4m / 1'4"
Image Coverage		FF $\Phi$ 43.3mm
Front diameter		95mm
Filter Size		82mm
EF mount <sup>2</sup>		131mm
Length	E-mount <sup>3</sup>	157mm
	PL mount <sup>4</sup>	123mm
EF mount		1560g
Weight <sup>5</sup>	E-mount	1620g
	PL mount	1470g
FF <sup>6</sup>		48.5°
S35 <sup>7</sup>		34.2°
APS-C <sup>8</sup>		33.0°

<sup>1</sup> Close focus distance is measured from the image plane <sup>2</sup> Front to EF mount flange <sup>3</sup> Front to E-mount flange <sup>4</sup> Front to PL mount flange <sup>5</sup> Without lens support foot <sup>6</sup> Horizontal angle of view for a full-frame camera aperture (aspect ratio 1:1.5, dimensions 36mm×24mm / 1.42"×0.94") <sup>7</sup> Horizontal angle of view for a super 35 digital cinema camera aperture (aspect ratio 1:1.8, dimensions 24.6mm×13.8mm / 0.97"×0.54") <sup>8</sup> Horizontal angle of view for an APS-C camera aperture (aspect ratio 1:1.5, dimensions 23.7mm×15.7mm / 0.93"×0.62") The specifications are subject to change without a notice.

## MTF chart

### Diffraction MTF

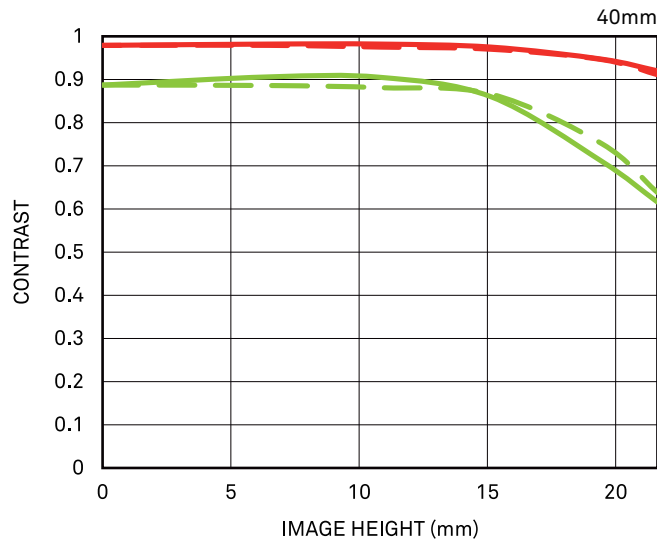

### Geometrical MTF

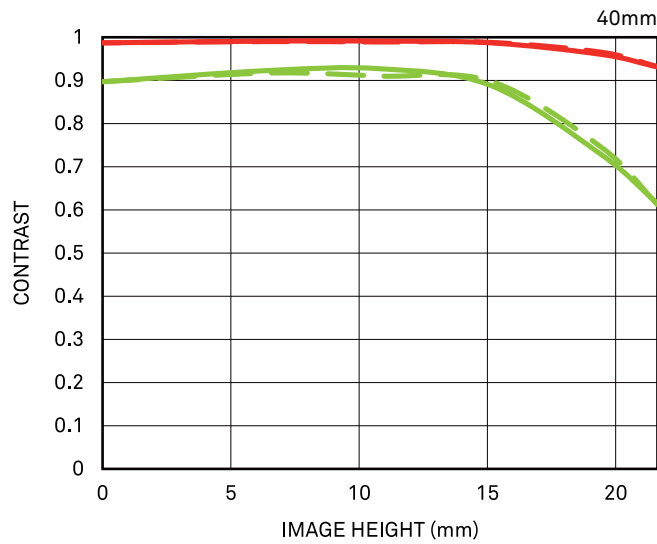

Spatial frequency	S	M
10 lp / mm		
30 lp / mm		

S : Sagittal Line  
M : Meridional Line

The MTF chart gives the result at the wide-open aperture.

### Distortion

#### Effective distortion

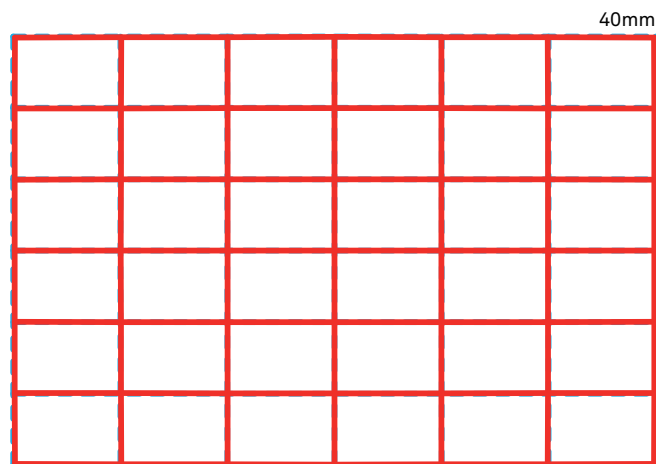

#### Relative distortion

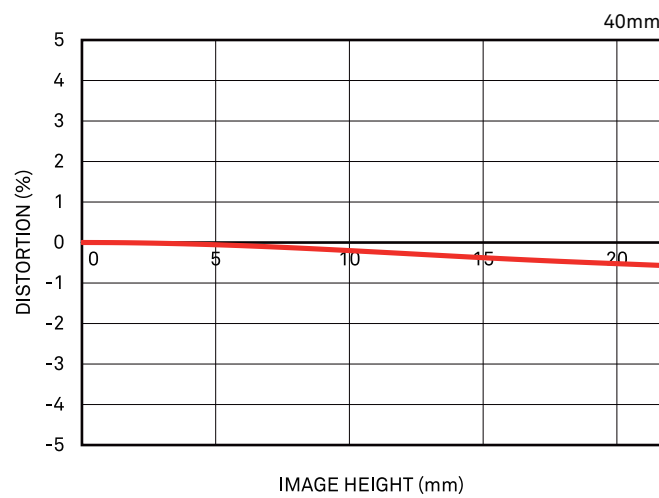

## Vignetting

